

# DAWN: Infrastructure for Usable Machine Learning

Peter Bailis, Kunle Olukotun, Chris Ré, Matei Zaharia



# It's the Golden Age of Data\*

Incredible advances in image recognition, natural language processing, planning, info retrieval

Society-scale impact: autonomous vehicles, personalized medicine, human trafficking

No end in sight for advances in ML

**\*for the best-funded, best-trained engineering teams**

# Building ML Products is Too Hard

Major successes (e.g., AlphaGo, ImageNet) require hundreds to thousands of engineers

Huge effort in data preparation, model tuning, experimentation, and productionizing

*Domain experts cannot easily or cheaply build ML products*

---

# Hidden Technical Debt in Machine Learning Systems

---

**D. Sculley, Gary Holt, Daniel Golovin, Eugene Davydov, Todd Phillips**  
{dsculley, gholt, dgg, edavydov, toddphillips}@google.com  
Google, Inc.

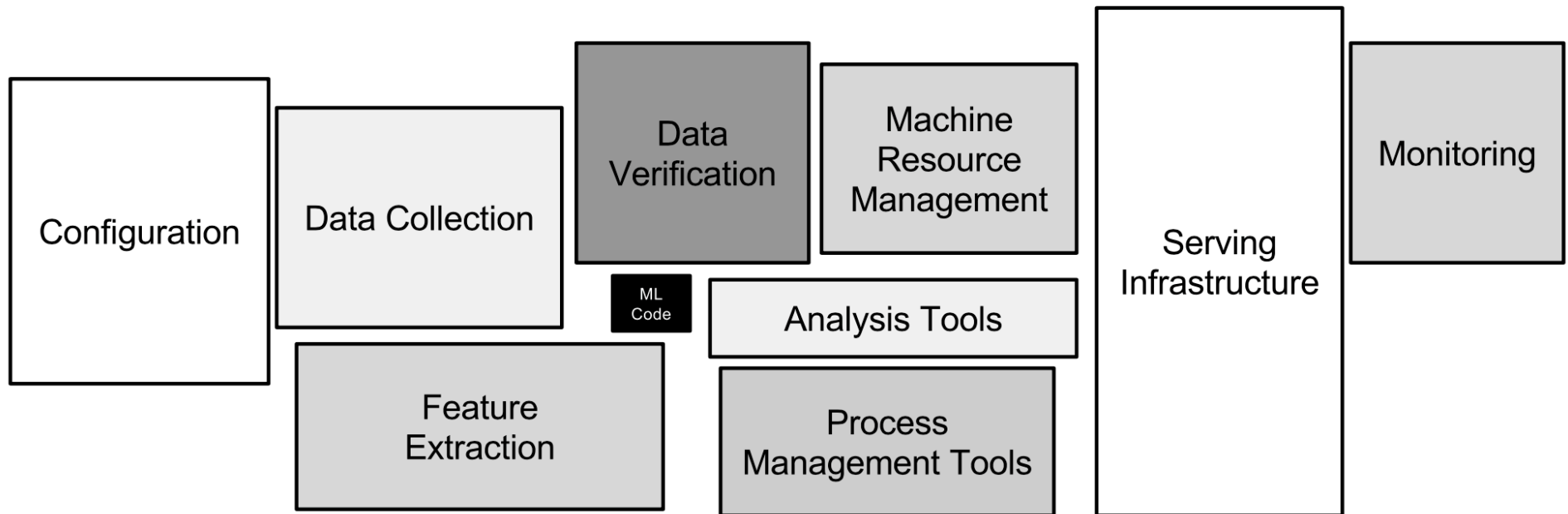

“Only a fraction of real-world ML systems is composed of ML code”

# The DAWN Question

What if *anyone* with domain expertise could build their own production-quality ML products?

- Without a PhD in machine learning
- Without being an expert in systems
- Without understanding the latest hardware

**It's happened before**

# It's happened before: Search

**Before:** Decades of research on information retrieval, indexes, ranking, etc

**After:** any developer can add search to an application by linking a library (e.g. Solr, Lucene); everyone (i.e., non-expert users) uses search

# It's happened before: SQL

**Before:** raw access to disk, manual layout of records, network databases (CODASYL)

**After:** SQL forms basis for transactional engines, data warehousing, business intelligence tools

**Key idea: end-to-end systems that tackle the barriers to access & production use**

# The DAWN Stack

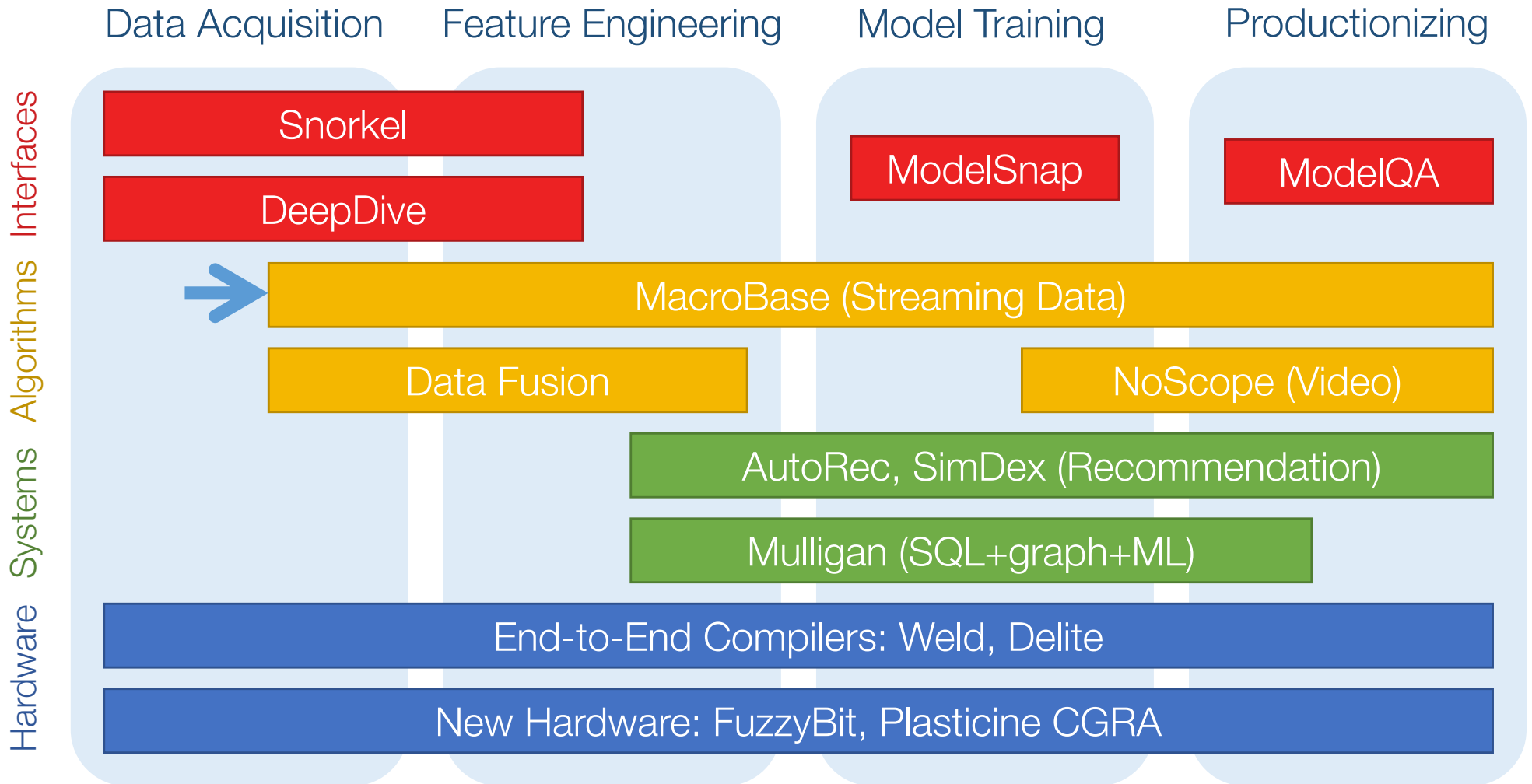

...



# Example: MacroBase for Continuous Analytics

End-to-end system to **prioritize user attention**



record_id	user_id	state	hw_make	hw_model	firmware_version	app_version	avg_temp	battery_drain	trip_time
131920	49e36c5b031141dd8cf240f7	CO	Lenovo	Lenovo_K910L	4.4.2	v21	79.252124	0.205834	40.910145
131921	a670eab2bc6d4e5991ea4269	WV	TCT (Alcatel)	4009A	7.1.1	v36	72.136380	0.184874	47.253076
131922	247c64e48a8743829c5f7199	UT	TCT (Alcatel)	4009A	7.1.1	v31	77.300103	0.230015	25.342140
131924	6bd9af7242ca480a96d75d0d	OH	HTC	HTC_M10u	6.0.1	v38	70.937014	0.454293	38.661611
131926	d449b12dcb6346d7af1021de	HI	HTC	HTC_Wildfire_S_A510b	6.0	v46	75.436764	0.151338	17.785555
131927	fff8907aa14e4a50ab76bd46	HI	bq	Aquaris_E4.5	4.4.1	v38	70.208187	0.286005	60.443799
131929	8226cd65bb1f4d61a6fcf455	MI	TCT (Alcatel)	ALCATEL_one_touch_97	6.0.1	v35	73.113370	0.249834	16.881133
131930	30e726fadc6744b2ace2d76b	LA	TCT (Alcatel)	ALCATEL_ONE_TOUCH_60	5.0	v40	77.918077	0.405417	51.163642
131931	569f35993da246f4afc83c2e	FL	Lava	S1	6.0.1	v44	76.558080	0.416760	42.252460
131932	9d2db241316c43378b8ec14c	AL	LGE	LG-D724	7.0	v29	76.760340	0.334446	37.922632
131933	484a1ced0a6a46468874861c	LA	Hisense	LED42K680X3DU	4.4.4	v49	77.138769	0.409485	23.345804
131934	d375d5a0e10d46cf9b91e343	MI	Techno	TECNO_P5S	6.0	v31	70.115019	0.179464	45.051123
131936	e4835a64d96e4e89997ce027	WI	ZTE	Z828	6.0.1	v35	71.615570	0.396389	47.662474
131937	cf00ae2105bb4e3cb43b64b2	FL	Spice	Spice_Mi-498H	5.0	v42	72.045184	0.327405	45.099422
131939	c94d264a846149f08f51c28e	RI	Infocus	InFocus_M320u	4.4.1	v49	73.543359	0.224504	19.069803
131940	c3c82947ab5a4d09b52afe21	MI							38.287879
131943	4e4566143b144be1809ad4d9	RI							28.306756
131944	0ee8ff83606b496392bedd49	NE							26.749918
131946	0ee8ff83606b496392bedd49	OK	LGE	LS670	4.0.4	v30	78.186519	0.381604	27.601968
131947	7a4bc4c56aa54d20b1119d42	NV	Oppo	F1f	4.3.1	v38	77.434095	0.436364	40.869723
131948	c3c82947ab5a4d09b52afe21	GA	Huawei	HUAWEI_Y320-U151	4.4.3	v42	77.715329	0.281726	23.077248
131949	2b0acf33a91f49b6aa70cbe5	MO	ZTE	KPN_Smart_300	4.4.4	v39	75.368614	0.371224	44.295975
131950	5aab0148ea794d2eacfc9a27	NV	Ketabket	TR10CS1	5.0	v49	79.459844	0.491424	37.653744

**Too much data for manual inspection  
Even harder when data is streaming**



Database Configuration

Database URL:

Base query:

Connected to postgres database!

Analyze

Schema Information and Selection

Clustering Attribute?	Target Metric? Lo/Hi	Name	Type
<input type="button" value="+"/> +	<input type="button" value="↓"/> ↓ <input type="button" value="↑"/> ↑	reading_id	int8
<input type="button" value="+"/> +	<input type="button" value="↓"/> ↓ <input type="button" value="↑"/> ↑	device_id	int8
<input type="button" value="+"/> +	<input type="button" value="↓"/> ↓ <input type="button" value="↑"/> ↑	state	varchar
<input type="button" value="+"/> +	<input type="button" value="↓"/> ↓ <input type="button" value="↑"/> ↑	model	varchar
<input type="button" value="+"/> +	<input type="button" value="↓"/> ↓ <input type="button" value="↑"/> ↑	firmware_version	varchar
<input type="button" value="+"/> +	<input type="button" value="↓"/> ↓ <input type="button" value="↑"/> ↑	temperature	numeric
<input type="button" value="+"/> +	<input type="button" value="↓"/> ↓ <input type="button" value="↑"/> ↑	power_drain	numeric

Column	Value
app_version	v50
hw_model	em_i8180
hw_make	Emdoor

*correlated attributes*

<b>Support:</b>	0.8226
<b>Ratio Out/In:</b>	472.92
<b>Records:</b>	849

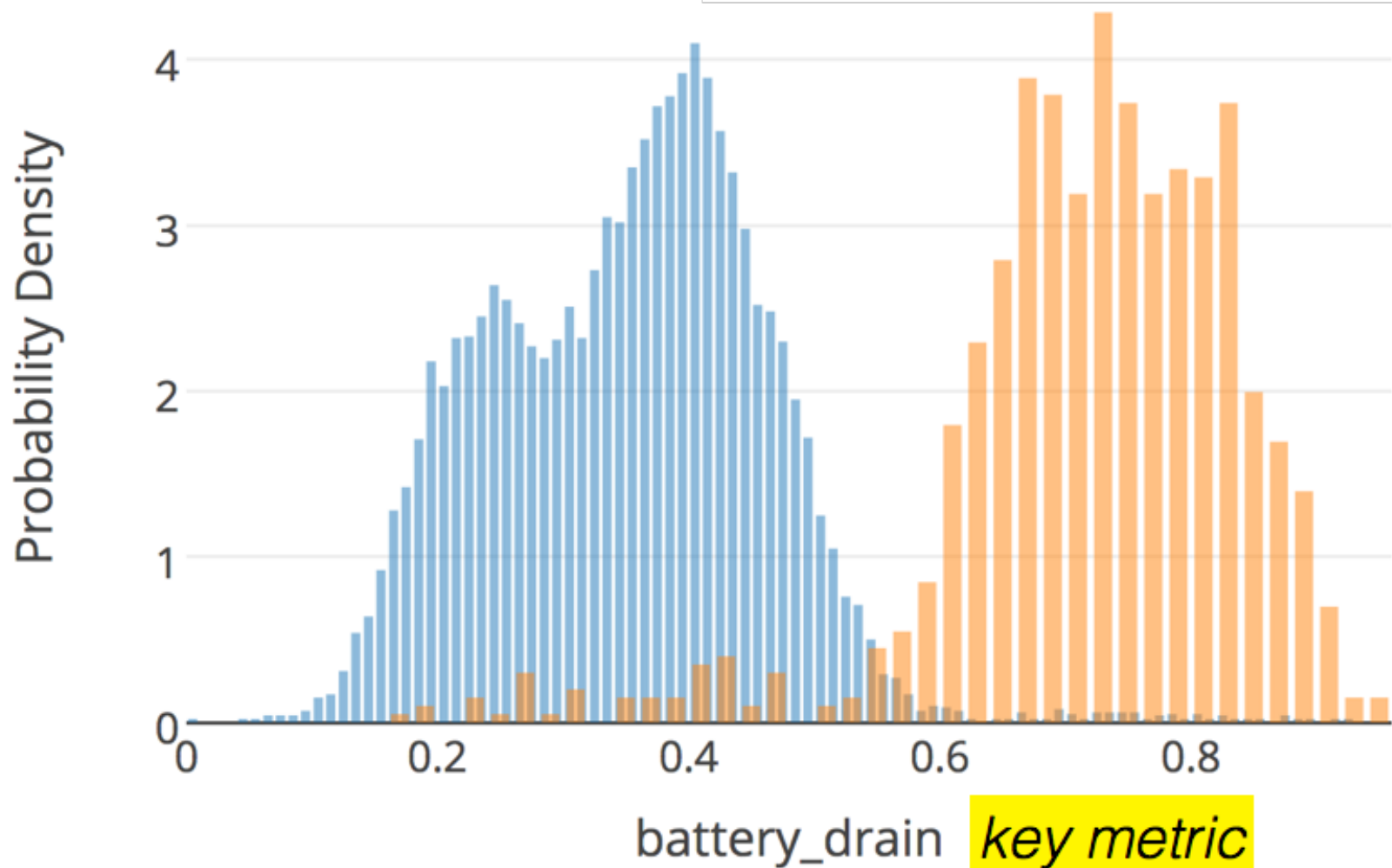

# MacroBase Query Architecture

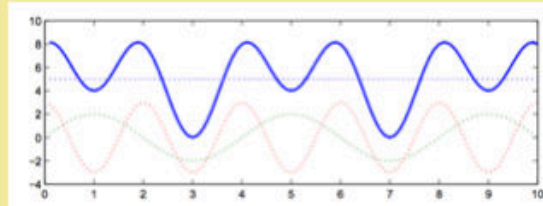
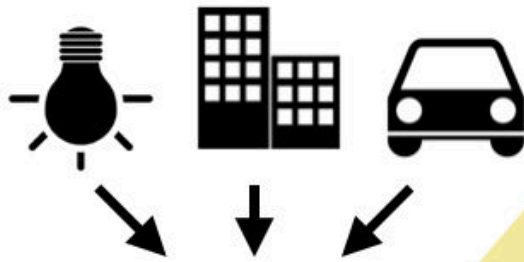

extract  
domain-specific  
signals

**FEATURE  
TRANSFORM**



**OUTLIER  
DETECTION**

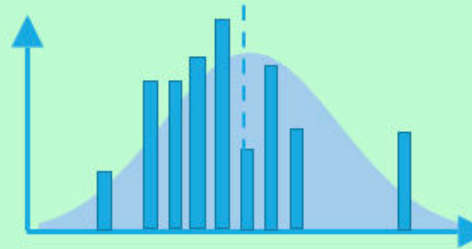

identify data  
in tails



**RESULT  
EXPLANATION**

find disproportionately  
correlated attributes

**Outliers**

{iPhone6, Canada}

{iPhone6, USA}

{iPhone5, Canada}

**Inliers**

{iPhone6, USA}

{iPhone6, USA}

{iPhone5, USA}

**ALERTS, REPORTS**

# MacroBase Summary

## End-to-end system to prioritize user attention

- No ML expertise needed: MacroBase uses general models and tunes them automatically
- No separate step for production use
- Co-design from algorithms to HW

*Early users: automotive, cloud, mobile apps, manufacturing*

Open source: [github.com/stanford-futuredata/macrobase](https://github.com/stanford-futuredata/macrobase)

# The DAWN Stack

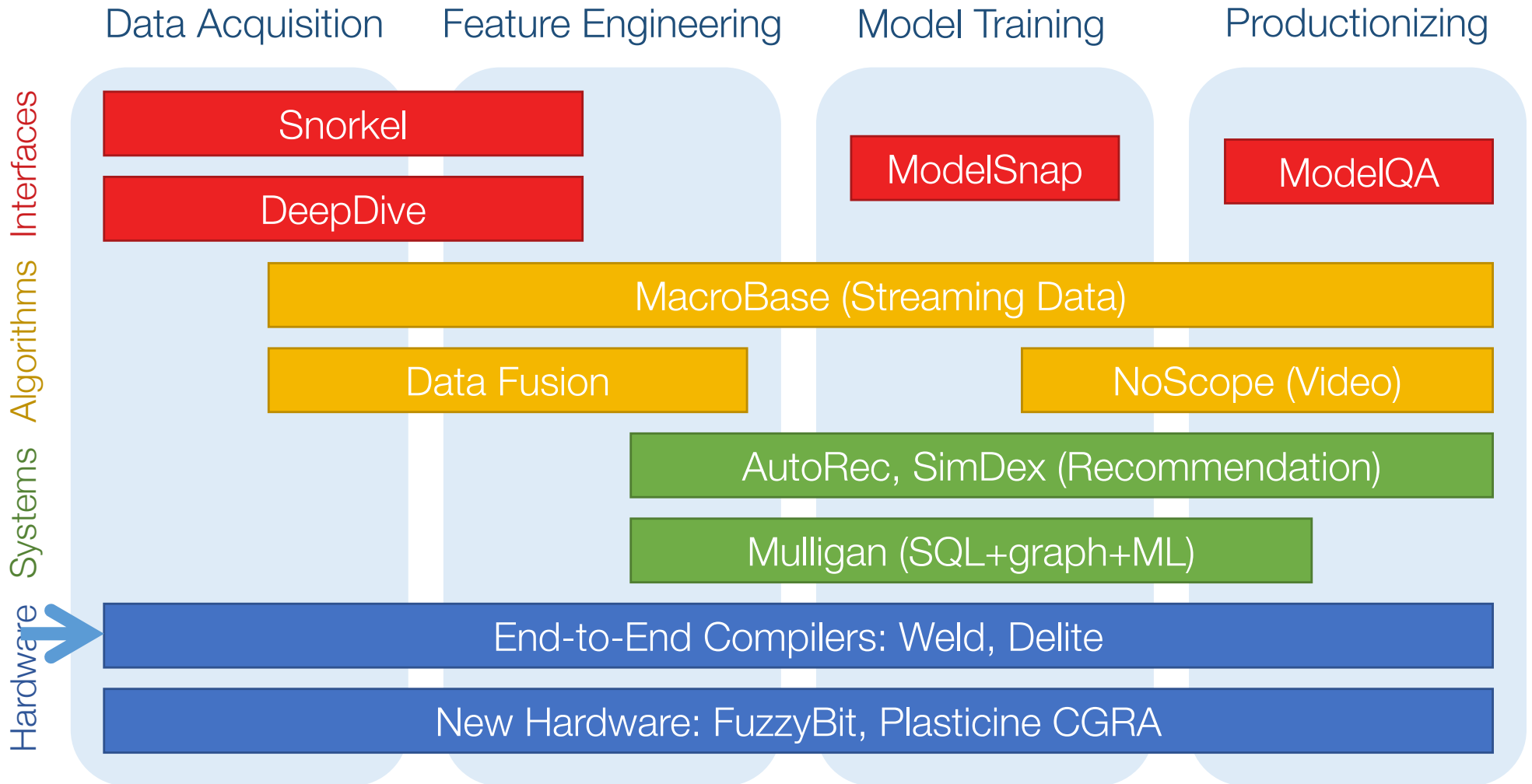

CPU



GPU



FPGA



Cluster



Mobile

...

# Weld: Rethinking the Interface to Data Analytics Libraries

**Standard approach:** users combine libraries using **function calls** that pass data via memory

**Problem:** for data-intensive apps, **data movement** cost dominates on modern hardware!

**5-30x** slowdowns in NumPy, Spark, TensorFlow, ...

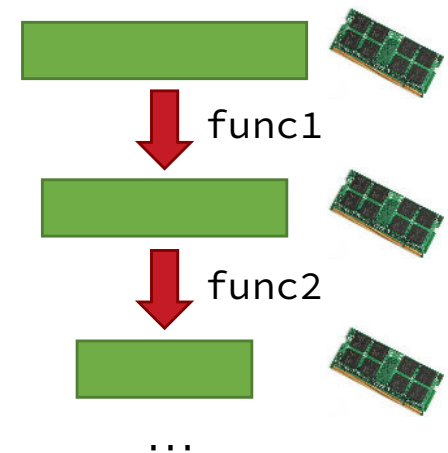



# Weld's Approach

**Diverse  
Analytics  
Tasks**

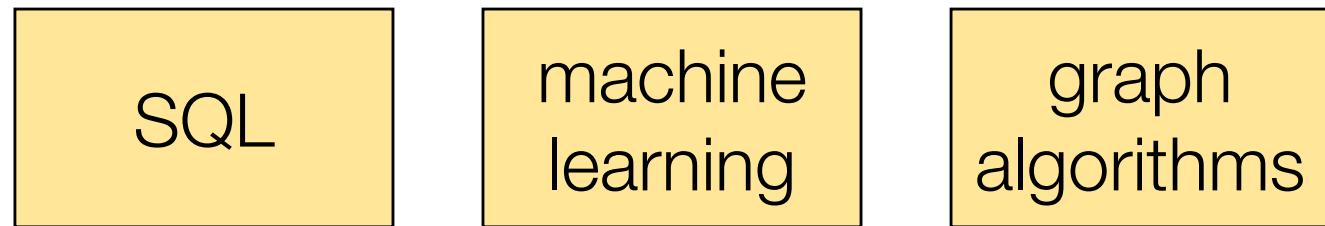

**Common  
Runtime**

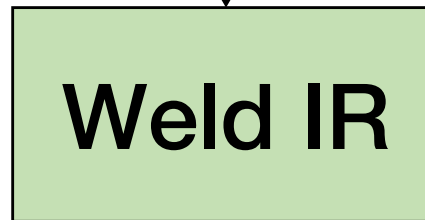

**Diverse  
Hardware  
Platforms**

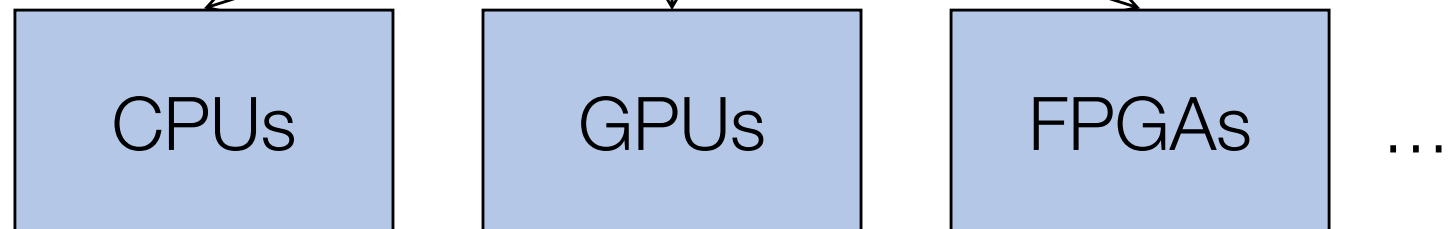

Open source: [weld.stanford.edu](http://weld.stanford.edu)

# Results: Existing Frameworks

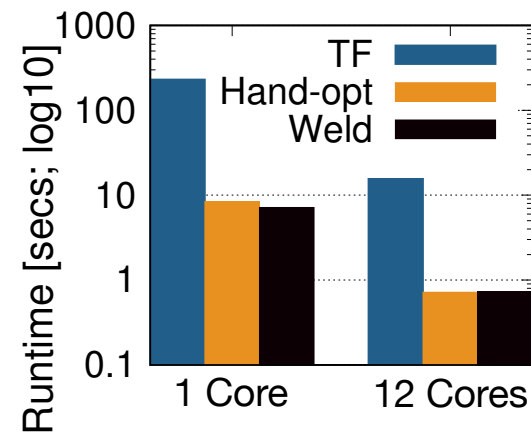
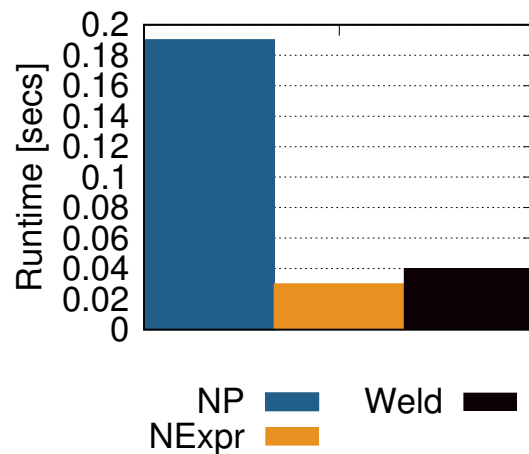
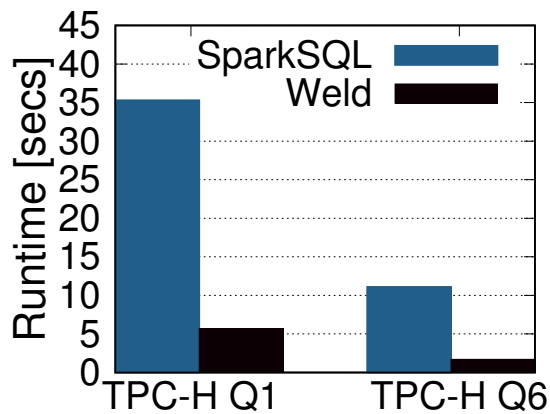

Integration effort: 500 lines glue, 30 lines/operator

# Results: Cross-Library Optimization

## Pandas + NumPy

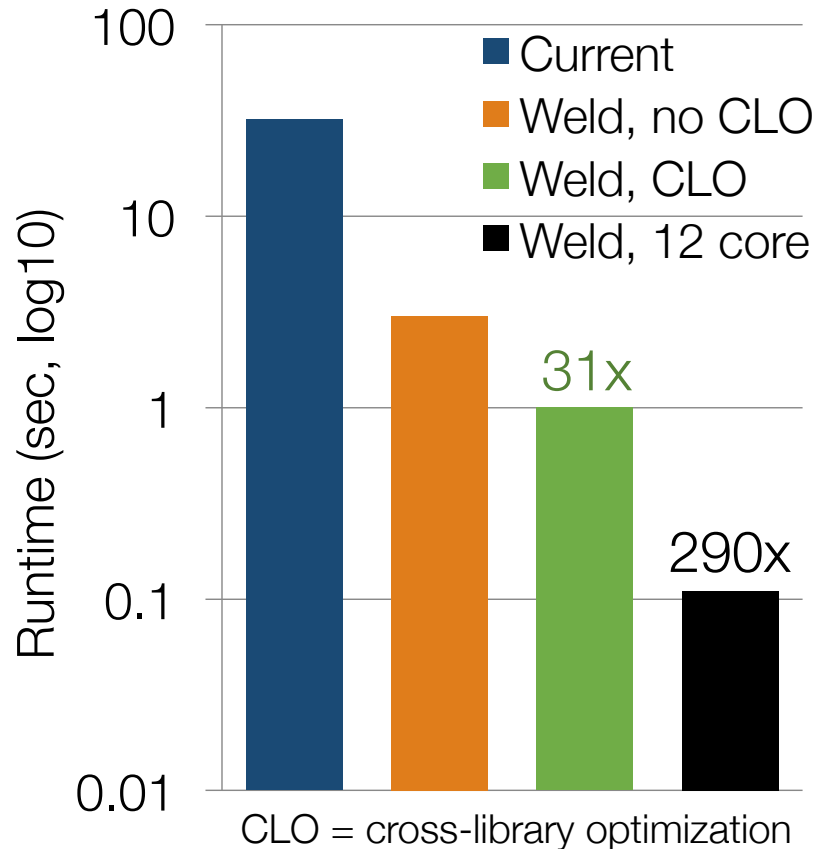

## Spark SQL UDF

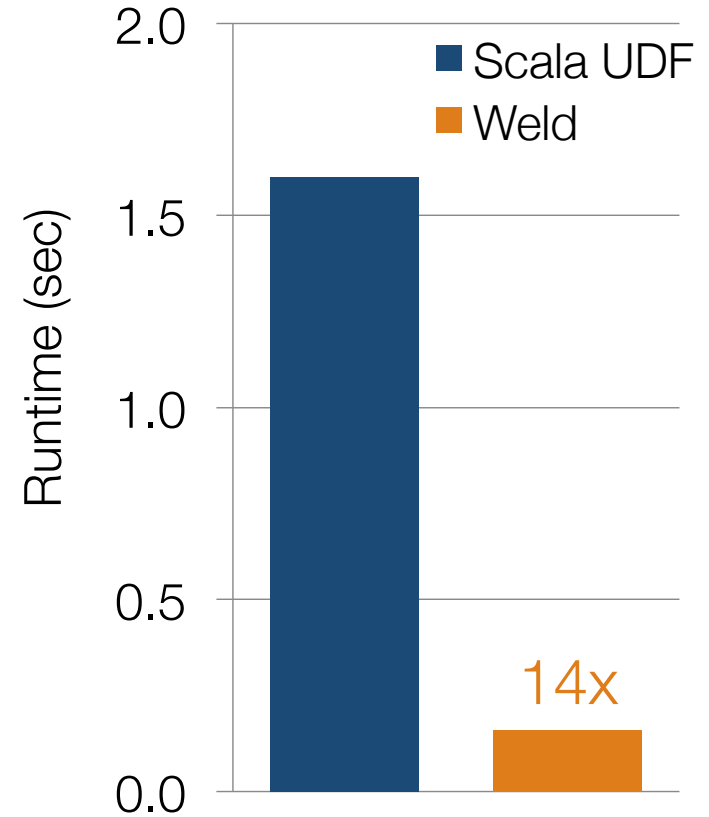

Open source: [weld.stanford.edu](http://weld.stanford.edu)

# The DAWN Stack

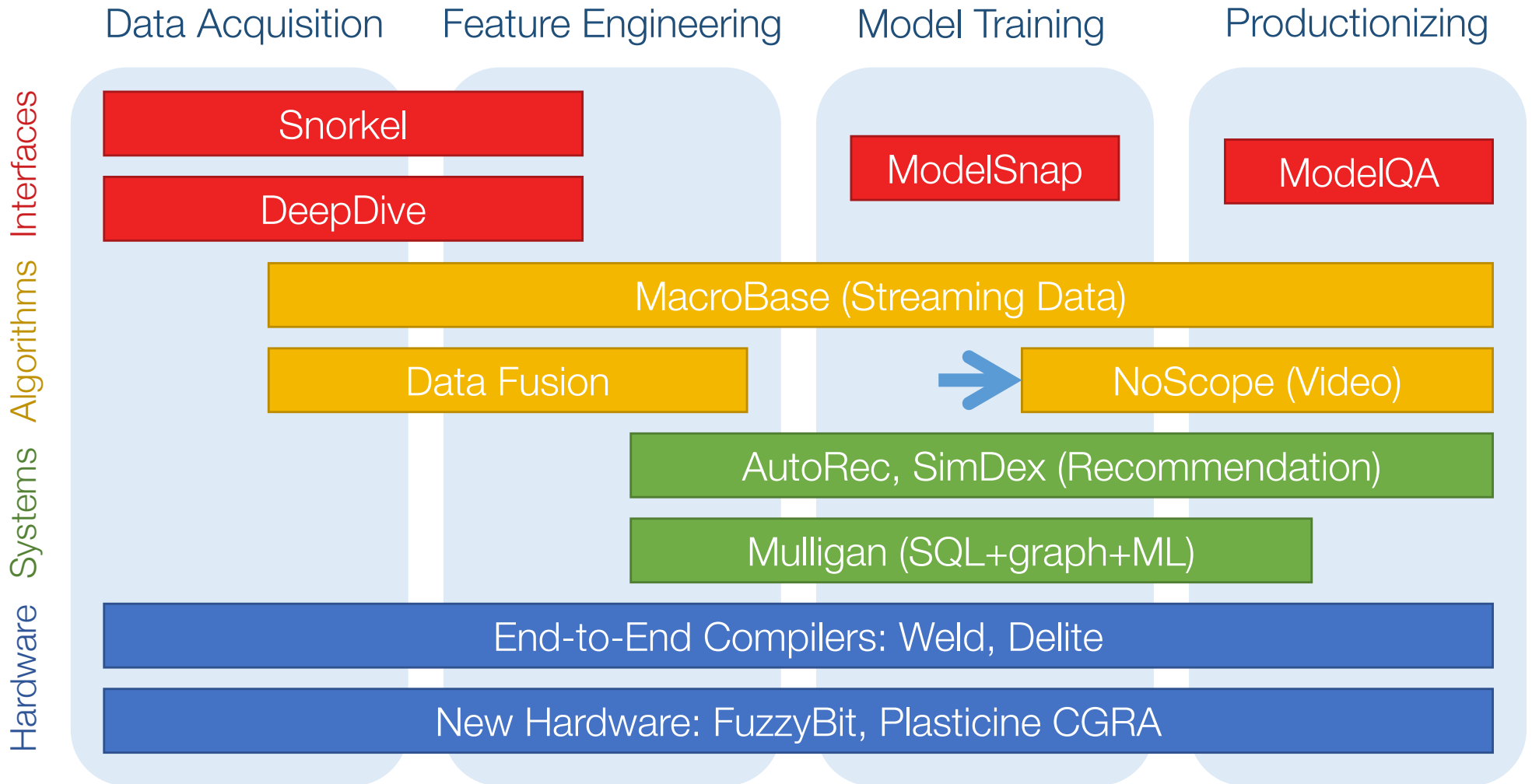

...

# NoScope: Fast CNN-Based Video Queries

**Opportunity:** CNNs allow more accurate queries on visual data than ever

**Challenge :** processing 1 video in real time requires a \$1000 GPU

**Result:** same accuracy but **100-3000x** faster through:

- Scene-specific distillation
- Temporal + spatial locality

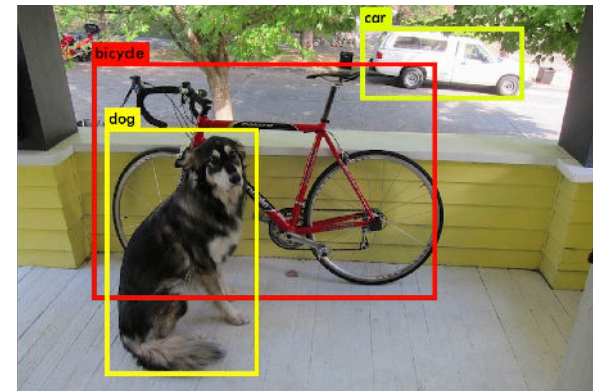

[bit.ly/NoScopeArxiv](http://bit.ly/NoScopeArxiv)

# The DAWN Stack

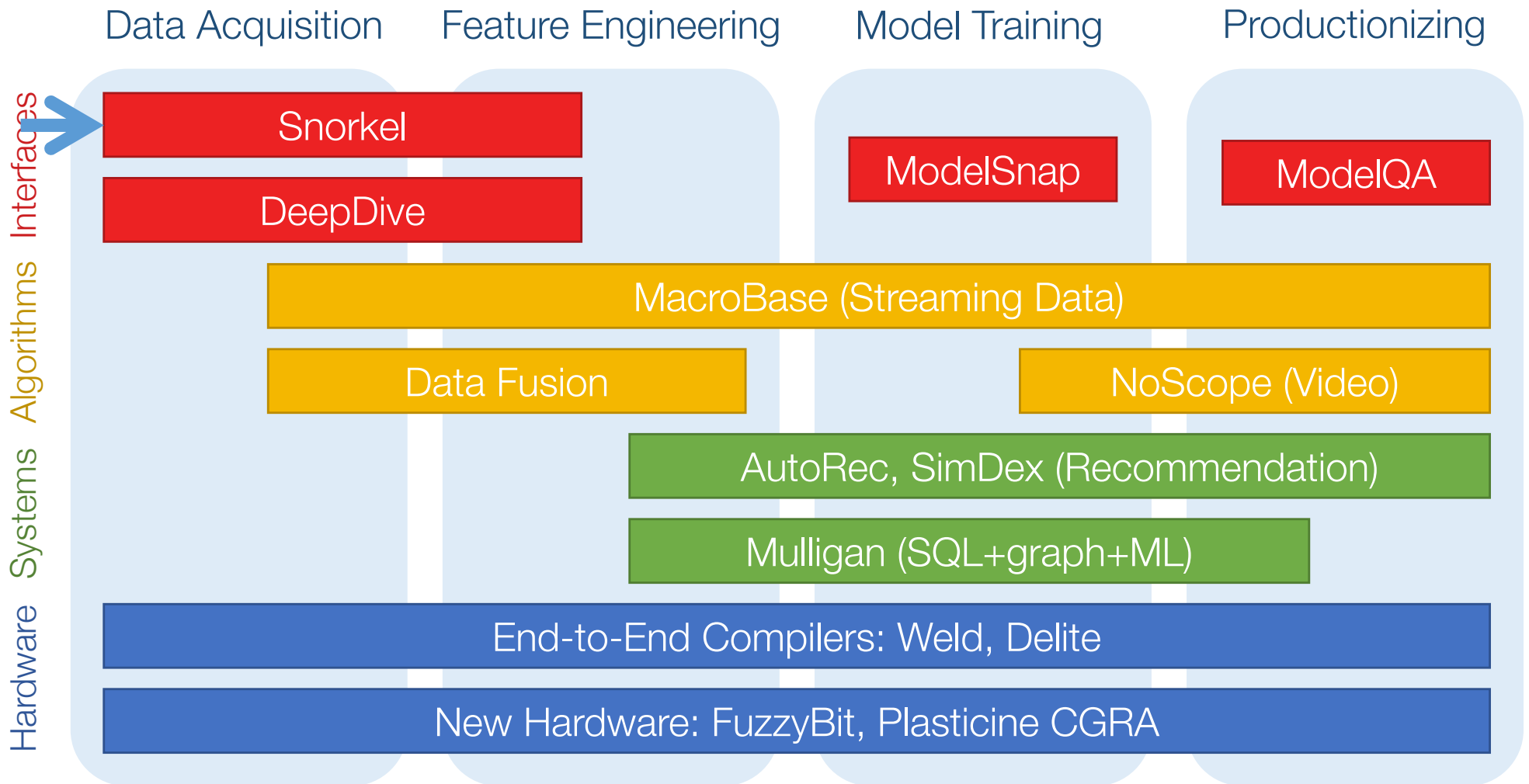

...

Training data is key enabler,  
barrier to entry



**The *New New* Oil**

**How can we leverage data that's  
expensive to label at scale?**

# Snorkel's Approach: Weak Supervision



- 1) User writes *labeling functions*: short programs that may not always give right label
  - E.g. regex to search in text
- 2) Snorkel simultaneously learns *noise* in LFs and a *noise-aware* target model (e.g. LSTM)

System	NCBI Disease (F1)	CDR Disease (F1)	CDR Chem. (F1)
TaggerOne (Dogan, 2012)*	<b>81.5</b>	79.6	<b>88.4</b>
Snorkel: Logistic Regression	79.1	79.6	<b>88.4</b>
Snorkel: LSTM + Embeddings	79.2	<b>80.4</b>	88.2

[github.com/HazyResearch/snorkel](https://github.com/HazyResearch/snorkel)



**DAWN: machine learning for everyone** via  
novel techniques and interfaces that span  
hardware, systems, and algorithms

Find out more at [dawn.cs.stanford.edu](http://dawn.cs.stanford.edu)



Peter Bailis



Chris Ré



Kunle Olukotun

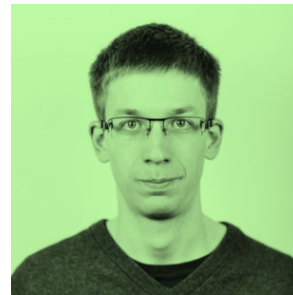

Matei Zaharia

